

## Treatment of Determination Method for Strength Characteristics of Reinforcing Steel by Using Thread Cutting Method after Temperature Influence

KOVALOV Andrii<sup>1,a\*</sup>, OTROSH Yuriy<sup>2,b\*</sup>, RYBKA Evgeniy<sup>2,c</sup>,  
KOVALEVSKA Tatiana<sup>2,d</sup>, TOGOBYTSKA Violeta<sup>2,e</sup> and ROLIN Ihor<sup>3,g</sup>

<sup>1</sup>Cherkassy Institute of Fire Safety of National University of Civil Defence of Ukraine,  
8, Onoprienko str., Cherkassy, Ukraine, 18034

<sup>2</sup>National University of Civil Defence of Ukraine, 94, Chernishevskaya str., Kharkov, Ukraine, 61023

<sup>3</sup>Military Institute of the Tank Troops of the National Technical University  
"Kharkiv Polytechnic Institute", 192, Poltava way str., Kharkov, Ukraine, 61000

<sup>a</sup>kovalev27051980@gmail.com, <sup>b</sup>yuriyotrosh@gmail.com, <sup>c</sup>rybka@nuczu.edu.ua, <sup>d</sup>rubiko@ukr.net,  
<sup>e</sup>leta-yczy@ukr.net, <sup>g</sup>rolin1964@gmail.com

**Keywords:** reinforcement samples, temperature influence, study of reinforcing steel, methods with local fracture.

**Abstract.** The article describes the results of an experiment that was done to develop a technique of reinforcement strength characteristics determination by using method of "thread cut", after various temperature effects on it.

### Introduction

Anthropogenic accidents or catastrophes cause an emergency situation, the sudden occurrence of which leads to significant human loss or damage to people, socio-environmental and economic losses, the need to protect people from harmful effects on the health of poisonous, radioactive substances, bacteria, trauma and psychogenic factors, carrying out rescue, emergency medical and evacuation measures, elimination of the negative consequences which have developed [1].

The problem of structures and machines operations, which are faced by all countries, is of great importance for Ukraine because of the difficult economic and financial situation. Particular attention is paid to the issues of managing the operational reliability and durability of objects by determining their technical condition and residual life [2, 3].

During the operation of structures, there is an accumulation of damage in the structure of the metal, which causes a change in its mechanical properties [4]. The causes of damage (soil subsidence, explosive wave action, seismic or fire effects) are generally similar [5]. In most cases, it is possible to repair and use reinforced concrete and metal structures of the emergency zone and areas of major damage after fire exposure [2]. It uses a small amount of new materials and saves time. Therefore, engineers are faced with the task of determining the actual strength characteristics of building materials of which existing load-bearing structures are made, for example, when inspecting buildings for the purpose of reconstruction, checking the load-bearing capacity of existing buildings, and the like. Therefore, the task of determining the actual strength characteristics of structures is relevant now.

### Analysis of Publications

The main feature of classification methods for determining the controlled parameters of reinforced concrete structures is the physical essence underlying the method. By the effect on construction, methods are divided into destructive, with local destruction and non-destructive.

In [6], destructive and non-destructive tests for structural materials were applied to evaluate the strength of concrete bridge structures supports after exposure to high temperatures. The obtained direct and non-direct results indicate that after compression of the sample under the influence of

high temperature, all compression methods show a decrease in compressive strength. The results also showed that the non-destructive testing method is effective because it also allows the internal physical characteristics of the samples to be checked. In addition, the combination of the ultrasonic pulse method and the elastic rebound method do not affect the accuracy of interpretation. However, it is obvious that any of those three methods can be adopted depending on the situation.

Evaluation of the technical condition of existing buildings using non-destructive testing methods is considered in paper [7]. Continuous monitoring of reinforced concrete structures using appropriate methods and existing reconstruction methods contributes to a significant reduction in the rate of operation of reinforced concrete structures, thereby increasing the service period of the structures. Non-destructive testing methods have a greater advantage in assessing the uniformity, durability, degree of corrosion of reinforcement in concrete, etc. for damaged structures.

The paper [8] provides principles and methods overview of assessing the technical condition of existing reinforced concrete structures, as well as the methods of work on assessing the technical condition for repair from the expert's point of view. Non-destructive testing methods, experimental material research methods, sample selection and evaluation options are also considered.

Recently, laser scanning technologies have become widespread in many areas of the modern economy [9]. The authors show the potential spectrum of the use of terrestrial laser scanning in the diagnosis of reinforced concrete elements and propose methods and techniques to practically reconstruct the failure process, as well as measure the geometry and evaluate the technical condition of the structures.

Non-destructive evaluation and laboratory studies of fire-damaged reinforced concrete structures are given in [10]. The application of methods of non-destructive testing and further laboratory examination of materials in assessing the degree of damage to the prefabricated structure by fire is considered. The results of non-destructive and laboratory testing were used to determine the degree of high-temperature damage to concrete and the potential impact on pre-stressed reinforcement.

Reinforcement studies in reinforced concrete structures are usually performed by non-destructive methods. This is due to the specificity of such structures and the inability to select samples of reinforcement for research without reducing performance, especially for bending elements. The presence of reinforcement is detected by magnetic and radiological methods. To determine the strength of the reinforcement from the structure, if possible without weakening, the samples are cut and tested in the laboratory. In determining the strength of reinforcement according to mechanical tests, the number of rods of one diameter and one profile, which must be selected from the same structures, must be at least three [11]. Under these conditions, there are difficulties in sampling.

### **Aim of Paper**

In order to extend the operational life of industrial buildings and structures, structures with clear signs of failure require reinforcement, and structures that lack these features require further investigation of the strength characteristics of the materials from which they are made [2, 12]. This is necessary to obtain a reliable assessment of the technical condition of the damaged structures, on the basis of which an efficient and cost-effective reconstruction project can be made.

### **Materials and Methods**

Therefore, in this paper we propose to consider the method of determining the strength characteristics of reinforcement, in reinforced concrete structures, which are operated after exposure to temperatures of different magnitude, without stopping the production process (if it has not been terminated during the fire).

For this purpose it is proposed to use the method of "thread cutting", because it is based on the local destruction of the structures being investigated and does not require the stopping of the technological process.

For testing the strength characteristics determining method of “thread cut” there were selected samples of reinforcing steel, without influence and after influence on them of different magnitude temperatures. They were all divided into groups according to the heating temperature [13, 14].

To check the reliability of obtained experiment results, they were compared with the values of the strength characteristics of the same samples obtained by calculations, the method of which is given in regulatory documents. Due to the fact that the maximum temperature of the reinforcement is 700 °C, it was decided to study more deeply the change of the characteristics of the strength of the reinforcing steel, depending on the temperature of heating (800 °C – 1000 °C).

There were three samples in each group of samples that were heated (the temperature of the groups was 100 °C, 200 °C, 300 °C, 400 °C, 500 °C, 600 °C, 700 °C, 800 °C, 900 °C, and 1000 °C, respectively).

There were 10 samples in the unheated group (20 °C). In half of them, the strength characteristics were investigated using the standard method, and in the remaining ones by the method of “thread cut”. Such an experiment program was also planned due to the need to confirm the validity of the results obtained by the proposed method of study. Strength characteristics were studied on A240C reinforcement (Ø14 specimens). St3 steel was used to make these reinforcement products.

For studies of the strength characteristics of the standard method, sample preparation did not involve any additional action. It was conducted in accordance with a normative document dedicated to this type of testing.

The length of the reinforcement steel specimens whose strength characteristics were investigated using the method proposed in this paper was identical to the length of the specimens prepared for the study by the standard method. But their preparation for the test included several additional points:

1. For the convenience of testing from each specimen, the strength of which was investigated by the method of “thread cut”, was cut off some of the metal required for leveling the surface. This cylindrical segment (simplified reinforcement steel is cylindrical) has a rectangle in which one side is equal to 8 mm and the other is the length of the sample. This is the size of the smaller side of the rectangle that is required for the test screw to be screwed in to the stop and perpendicular to the test surface throughout the experiment. This is required by the technology of determining strength characteristics by the method under consideration. To meet this requirement, a special test screw design was provided - with a thrust ring. The size of a piece of metal cut from the sample (in fig. 1, this size is indicated by - c) depends on the size of the thrust ring, which in turn depends on the diameter of the test screw (Ø5 mm), which is constant during the whole experiment. The height of this segment (in Fig. 1) depends on the diameter of the test specimen and is:

$$b = r - \frac{1}{2}\sqrt{4r^2 - c^2} \quad (1)$$

where  $r$  – is the radius of the test sample;

2. The technology of determining the strength characteristics using the method of "thread cut" provides by drilling holes and cutting them in the thread in the test pieces of reinforcement. In all samples, drilling of holes (Ø4.2 mm drill) and thread cutting (with M5H1 brand tap) were performed by the same type of tool with high accuracy of observing the technology of work execution. It is important that these measures take place perpendicular to the surface of the test specimens. There were two openings in each of the specimens whose tensile strength was investigated.

The program of preparation of temperature-influenced fittings included initially heating each group of samples to a certain temperature in the muffle furnaces, followed by gradual cooling naturally to room temperature, and then preparing them according to paragraphs 1 and 2.

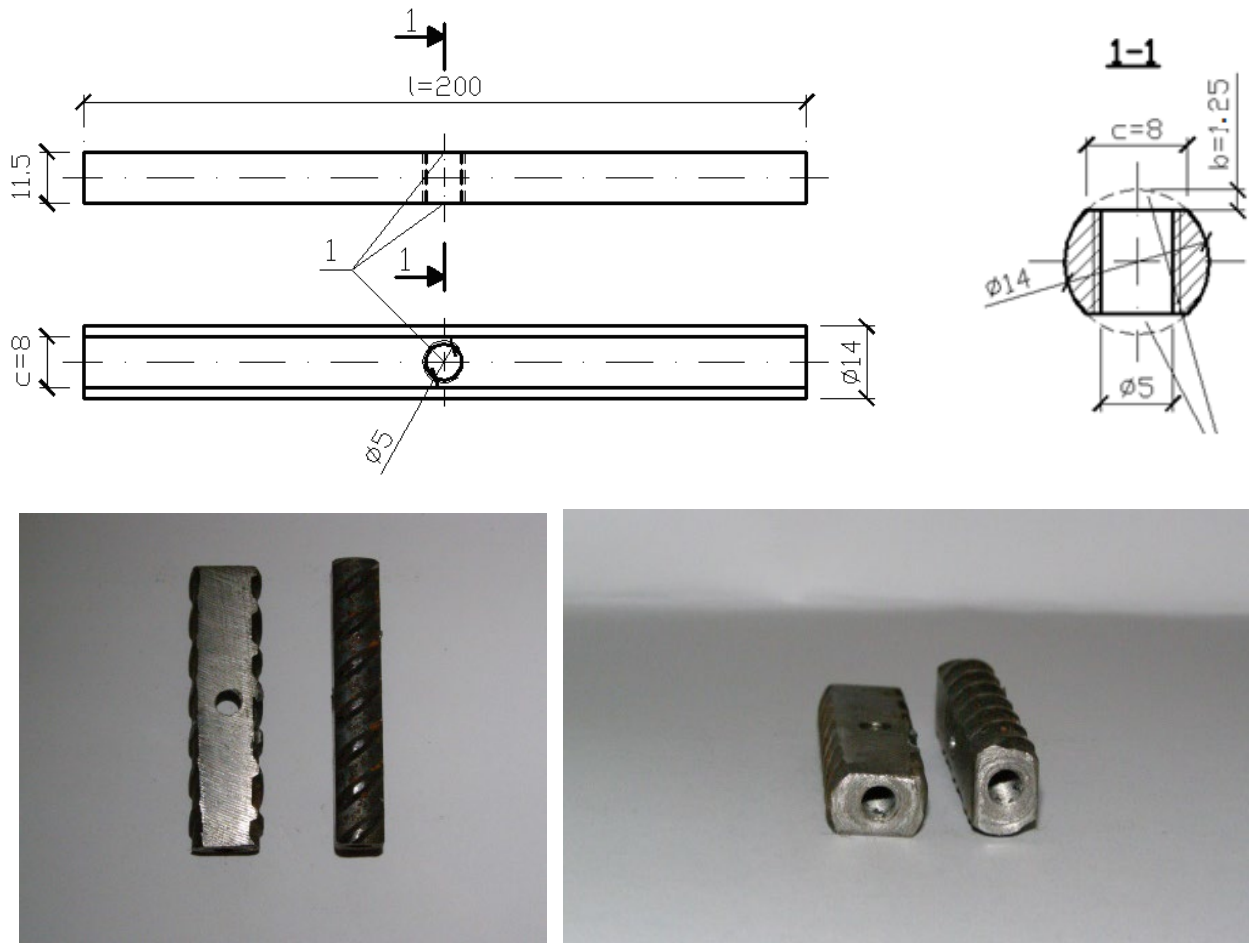

Fig. 1 Appearance of test samples of reinforcing steel prepared to determine the strength characteristics by a “thread cut” (for example, a sample of Ø14 mm reinforcement steel, class A240C)

Simply put, the experiment was reduced to the destruction of connections that were formed from the test screw and the test material (samples of fittings, whose properties were determined by the “thread cut”).

Regulatory documents propose to determine the strength characteristics of the reinforcement depending on the temperature of influence ( $R_{at}, R_{at}^0$ ) using the properties of the reinforcement, determined under normal conditions ( $R_a$ ) using coefficients  $m_{at}$  (heated) or (after heating and cooling), which take into account the reduction of steel resistance by formulas:

– in the heated state

$$R_{at} = m_{at} R_a \quad (2)$$

– after heating and cooling

$$R_{at}^0 = m_{at}^0 R_a \quad (3)$$

This paper deals with the case when determining the strength characteristics of reinforcing steel after heating and cooling. For the class to which the reinforcement specimens belong, the coefficient (temperature range – 100 °C – 700 °C) is equal to one.

The strength characteristics obtained after the experiment and some calculations are summarized in Table 1.

Table 1 Strength characteristics of reinforcement samples after temperature influence on them

The method by which the strength characteristics were determined	Strength characteristics	Heating temperature, [°C]						
		100	200	300	400	500	600	700
“Thread Cut”	$R_{yn}^f$	421.07	420.02	418.97	417.92	417.74	417.57	411.41
	$R_{un}^f$	483.97	483.05	482.13	481.21	480.3	470.34	461.61
According to the calculations (under normal conditions the beats were determined by the standard)	$R_{yn}^f$	414.0	414.0	414.0	414.0	414.0	414.0	414.0

## Conclusions

1. The values of the strength characteristics (both by the proposed method and by the standard method) obtained during the experiment are higher than the values of the same characteristics as those specified in the normative literature by 48% ( $R_{yn}$ ) and 18% ( $R_{un}$ ) (Table 1). This shows to the need of determination the actual strength characteristics of materials during the structures examination that were affected by the influence of a rapid rise of temperature, and to develop an effective and cost-effective reconstruction project.

2. When comparing the values of the strength characteristics of the reinforcement samples after temperature exposure obtained by the “thread cut” and calculated according to the method described in the regulatory documents, it is clear that the difference between them are not that big. Namely: in the yield strength of steel it changes from 1.68% (at 100 °C) to 0.62% (at 700 °C); in temporary tear resistance – from 5.9% (at 100 °C) to 1.37% (at 700 °C). This discrepancy between the difference between the strength characteristics indicates that although the proposed research method is indirect, its accuracy is sufficient to establish the strength characteristics when inspecting the structures are used.

3. A deeper study of reinforcing steel properties after temperature exposure is much greater than it was considered in the normative literature showed that the yield strength of steel in comparison with the indicator to temperature influence decreases by 2.9% (at 800 °C), by 3.12% (at 900 °C) and 4.05% (at 1000 °C); temporary resistance – by 2.7% (at 800 °C), by 2.9% (at 900 °C) and by 3.9% (at 1000 °C). The loss of strength characteristics up to 700 °C inclusive is not big and is 1.5% ( $R_{yn}$ ) and 1.7% ( $R_{un}$ ), as it should be, judging by the method of calculations of these strengths given in the normative literature.

4. With the increase of temperature influence (more than 700 °C), there is not only more significant loss of strength, but also the appearance of such samples of reinforcement begins to differ significantly.

**References**

- [1] V.V. Tiutiunyk, H.V. Ivanets, I.A. Tolkunov, E.I. Stetsyuk, System approach for readiness assessment units of civil defense to actions at emergency situations, *Naukovyi Visnyk Natsionalnoho Hirnychoho Universytetu* 1 (2018) 99–105.
- [2] Y. Otrosh, A. Kovalov, O. Semkiv, I. Rudeshko, V. Diven, Methodology remaining lifetime determination of the building structures, *MATEC Web of Conferences*. 230 (2018) 02023.
- [3] V.A. Andronov, Yu.M. Danchenko, A.V. Skripinets, O.M. Bukhman, Efficiency of utilization of vibration-absorbing polimer coating for reducing local vibration Terms and conditions Privacy policy, *Naukovyi Visnyk Natsionalnoho Hirnychoho Universytetu*. 6 (2014) 85–91.
- [4] Y. Otrosh, O. Semkiv, E. Rybka and A. Kovalov, About need of calculations for the steelframework building in temperature influences conditions, *Materials Science and Engineering*. 708 (2019) 012065.
- [5] A. Vasilchenko, E. Doronin, B. Ivanov, V. Konoval, Effect of residual deformation of a steel column on its fire resistance under combined exposure “explosion-fire”, *Materials Science Forum*. 968 (2019) 288–293.
- [6] Stephen Kolo, Adeleke Oluwafemi, Yusuf Ibrahim, E.N. Olise, Aminulai Hammed, A. Abdullahi, Assessment of Compressive Strength of Concrete Bridge using Destructive/Non-Destructive Tests at Elevated Temperature, *Epistemics in Science, Engineering and Technology*. 6 (2016) 418–422.
- [7] Enkatesh Preethi, Alapati Mallika. Condition Assessment of Existing Concrete Building Using Non-Destructive Testing Methods for Effective Repair and Restoration-A Case Study, *Civil Engineering Journal*. 3 (2017) 841.
- [8] U. Dilek, Condition assessment of concrete structures, *Failure, Distress and Repair of Concrete Structures*. (2009) 84–137.
- [9] Janowski Artur, Nagrodzka-Godycka Krystyna, Szulwic Jakub, Ziółkowski Patryk, Remote sensing and photogrammetry techniques in diagnostics of concrete structures, *Computers and Concrete*. 18 (2016) 405–420.
- [10] M. Reis, U. Dilek, Non-Destructive Evaluation and Laboratory Testing of a Concrete Structure Damaged by Fire, *Forensic Engineering 2012: Gateway to a Better Tomorrow - Proceedings of the 6th Congress on Forensic Engineering*. (2012) 1159–1166.
- [11] Rukovodstvo po jekspluatacii stroitel'nyh konstrukcij proizvodstvennyh zdaniy promyshlennyh predpriyatij, Moskva, 1995. 99 s.
- [12] A. Kovalov, Y. Otrosh, M. Surianinov, T. Kovalevska, Experimental and computer researches of ferroconcrete floor slabs at high-temperature influences, in *Materials Science Forum*. 968 (2019) 361–367.
- [13] V. Andronov, B. Pospelov, E. Rybka, Increase of accuracy of definition of temperature by sensors of fire alarms in real conditions of fire on objects, *EasternEuropean Journal of Enterprise Technologies*. 4 (5–82) (2016) 38–44.
- [14] V. Andronov, B. Pospelov, E. Rybka, S. Skliarov, Examining the learning fire detectors under real conditions of application, *Eastern European Journal of Enterprise Technologies*, 3 (9–87) (2017) 53–59.